



one-wall workshop

Materials & Cutting Diagram

STORAGE CABINET WORK AREA

A	Top	16 x 71 - 3/4" MDF	L	End Edging	3/4 x 1 1/2 - 19 1/4
B	Bottom	15 1/2 x 71 - 3/4" MDF	M	Bottom Panel	12 x 72 - 3/4" MDF
C	Left/Right End (2)	13 5/8 x 16 - 3/4" MDF	N	Panel Blocking (2)	1 x 1 1/2 - 72
D	Dividers (2)	11 7/8 x 15 1/4 - 3/4" MDF	O	Panel Edging	1 3/4 x 72 - 3/4" MDF
E	Back	13 1/8 x 71 - 3/4" MDF	P	Top Panel	18 x 72 - 3/4" MDF
F	Bottom Fillers (2)	3/4 x 1 1/2 - 70 1/2	Q	Front Light Rail	2 1/4 x 72 - 3/4" MDF
G	Face Frame Rails (2)	3/4 x 11/2 - 69	R	Pegboard	18 x 72 - 1/4" Pgbd.
H	Face Frame Outer Stiles (2)	3/4 x 1 1/2 - 13 5/8	S	Horizontal Spacer (2)	3/4 x 1 1/4 - 72
I	Face Frame Center Stiles (2)	3/4 x 1 1/2 - 10 5/8	T	Vertical Spacers (2)	3/4 x 1 1/4 - 15 1/2
J	Tops (2)	18 1/2 x 72 - 3/4" MDF			
K	Front Edging	3/4 x 1 1/2 - 72 3/4			

STORAGE CABINET WORK AREA

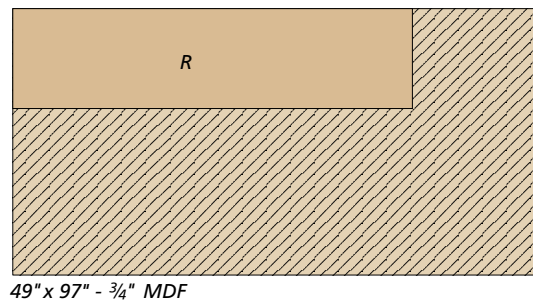
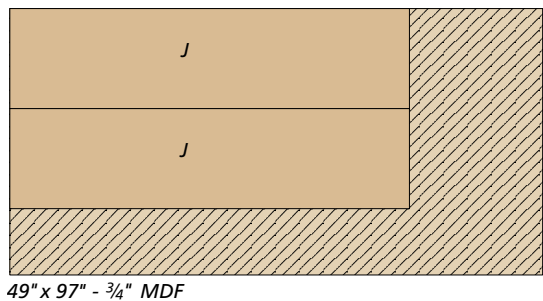
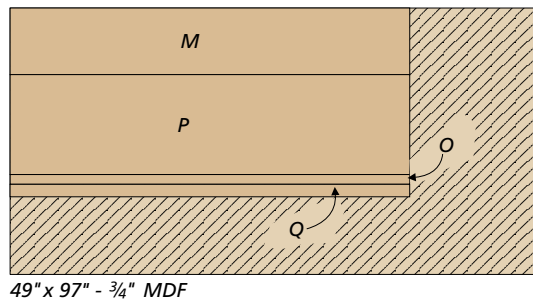
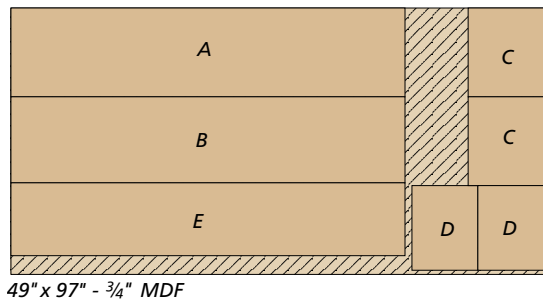
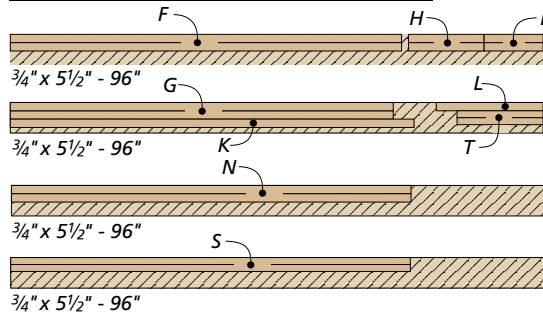

WORKBENCH AREA

U	Top	16 x 59 - 3/4 MDF	FF	Tops (2)	18 1/2 x 24 - 3/4 MDF
V	Bottom	15 1/2 x 59 - 3/4 MDF	GG	Front Edging	3/4 x 1 1/2 - 24
W	Left/Right End (2)	13 5/8 x 16 - 3/4 MDF	HH	Top (3)	7 3/4 x 54 1/2 - 3/4 MDF
X	Back	13 1/8 x 59 - 3/4 MDF	II	Rails (3)	3/4 x 2 1/4 - 54 1/2
Y	Partitions (4)	11 7/8 x 15 1/4 - 3/4 MDF	JJ	Left/Right End (2)	3/4 x 2 1/4 - 12 1/4
Z	Top Supports (2)	11 3/8 x 18 1/4 - 3/4 MDF	KK	Vise Dog Run (3)	3/4 x 2 1/4 - 42
AA	Face Frame Rail	3/4 x 1 1/2 - 57	LL	Vise Guide Strips (2)	3/4 x 1/4 - 10
BB	Face Frames Stiles (2)	3/4 x 1 1/2 - 13 5/8	MM	Vise Traveler Block (3)	3/4 x 2 1/4 - 3
CC	Tops (2)	18 1/2 x 60 - 3/4 MDF	NN	Vise Mounting Block (3)	3/4 x 2 1/4 - 2 1/2
DD	Front Edging	3/4 x 2 1/4 - 60	OO	Support Wedges (2)	3/4 x 1/2 - 9
EE	Filler Strip	3/4 x 2 1/2 - 60			

WORKBENCH AREA

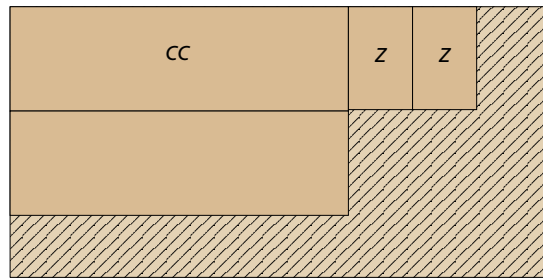
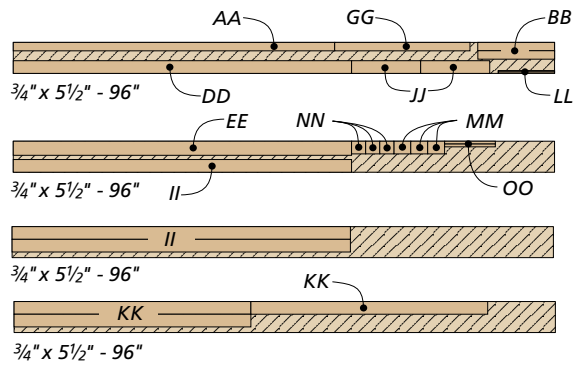

49" x 97" - 3/4" MDF

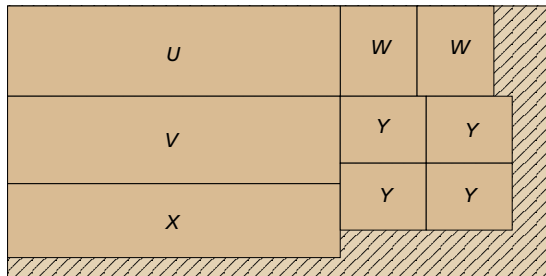

49" x 97" - 3/4" MDF

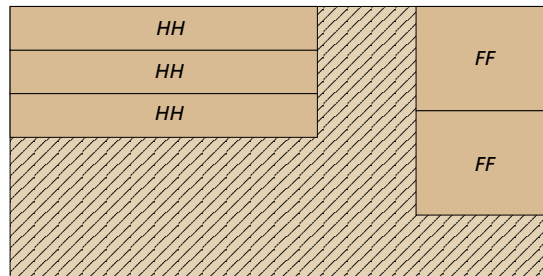

49" x 97" - 3/4" MDF

ADDITIONAL STORAGE

PP Top	22 1/2 x 24 - 3/4 MDF	AAA Front Light Rail	2 1/4 x 84 - 3/4 MDF
QQ Sides (2)	2 1/2 x 24 - 3/4 MDF	BBB Pegboard	18 x 24 - 1/4 Pgbd.
RR Front Face	2 1/2 x 23 3/4 - 3/4 MDF	CCC Top/Bottom Spacer (2)	3/4 x 1 1/4 - 24
SS Flange (2)	3 1/4 x 24 - 3/4 MDF	DDD End Spacers (2)	3/4 x 1 1/4 - 15 1/2
TT Shelves (2)	7 x 59 - 3/4 MDF	EEE Pegboard	18 x 60 - 1/4 Pgbd.
UU Front/Back Edging (4)	3/4 x 1 1/4 - 60	FFF Top/Bottom Spacer (2)	3/4 x 1 1/4 - 60
VV End Edging (4)	3/4 x 1 1/4 - 8	GGG End Spacers (2)	3/4 x 1 1/4 - 15 1/2
WW Bottom Panel	12 x 84 - 3/4 MDF	HHH Shelves (2)	3/4 x 5 3/4 - 22
XX Panel Blocking (2)	1 x 1 1/2 - 84	III Back Panels (2)	3/4 x 6 - 22
YY Panel Edging	1 3/4 x 84 - 3/4 MDF	JJJ Ends (4)	3/4 x 6 - 6
ZZ Top Panel	18 x 84 - 3/4 MDF		

ADDITIONAL STORAGE

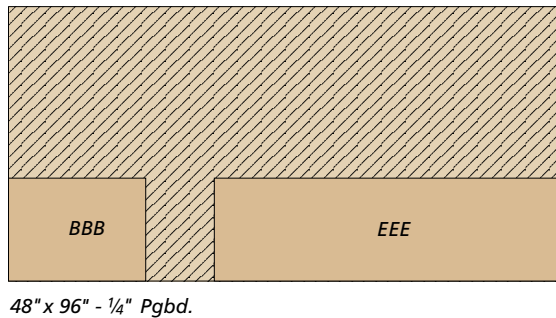
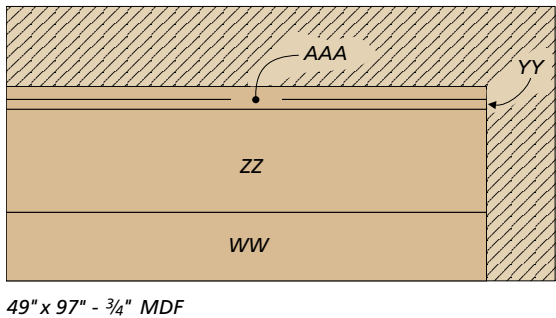
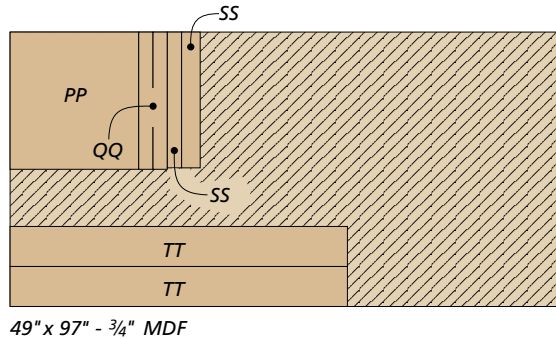
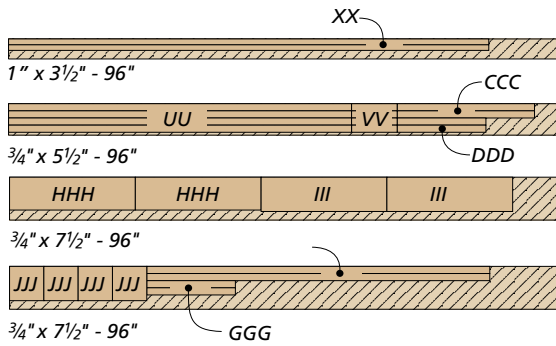

NOTE: IF BUILDING THE ENTIRE ONE-WALL WORKSHOP, SHEET GOOD PARTS CAN BE COMBINED TO MINIMIZE SHEET REQUIREMENTS